

PRODUCT RANGE.

Horizontal pumps

with hydrodynamic shaft seal

Vertical pumps

- for dry installations, short design
- for wet installations, without bearing in the liquid
- for wet installations, with slide bearing
- with feeder propeller for space-saving installation

Tank pumps

with in-feed from above

Horizontal and vertical pumps

- with half-open impellers
- with closed impellers
- with torque flow impellers

Downstream seals

for pumps with hydrodynamic relief of the shaft gap

- packed gland
- mechanical seal
- magnetic drive
- particular solution for problem cases

Comprehensive information about each type of pumps is featured in individual product brochures.

MATERIALS.

- all castable and weldable stainless steel qualities
- castable and weldable special alloys
- grey cast iron, rubber lined
- special materials such as titanium, zirconium, etc.

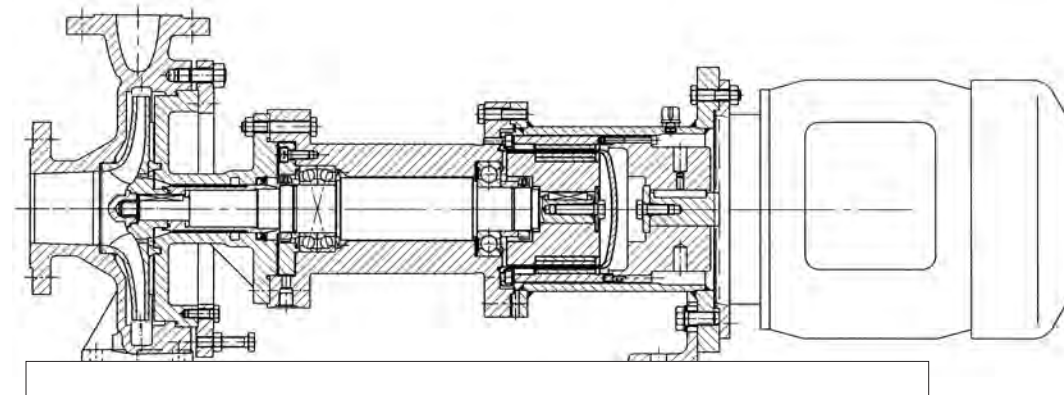

BUNGARTZ
CENTRIFUGAL PUMPS
MPCH**DryRun**

PAUL BUNGARTZ GMBH & CO. KG

Düsseldorfer Straße 79
D – 40545 Düsseldorf / Germany
Phone +49 211 57 79 05 - 0
Fax +49 211 57 79 05 - 12
www.bungartz.de
pumpen@bungartz.de

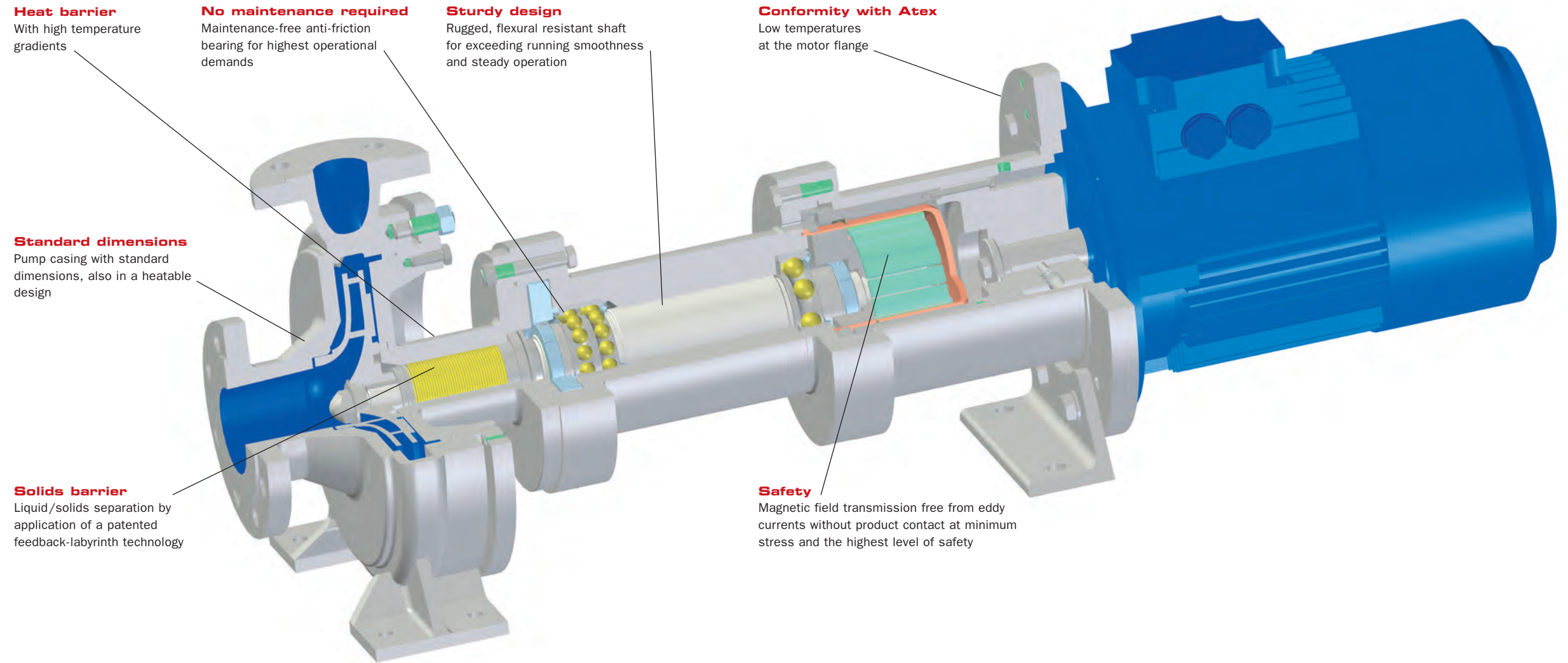

Heat barrier
With high temperature gradients

No maintenance required
Maintenance-free anti-friction bearing for highest operational demands

Sturdy design
Rugged, flexural resistant shaft for exceeding running smoothness and steady operation

Conformity with Atex
Low temperatures at the motor flange

Standard dimensions
Pump casing with standard dimensions, also in a heatable design

Solids barrier
Liquid/solids separation by application of a patented feedback-labyrinth technology

Safety
Magnetic field transmission free from eddy currents without product contact at minimum stress and the highest level of safety

SAFE IS SAFE.
THE CENTRIFUGAL PUMP WITH MAGNETIC DRIVE MPCHDryRun.

The MPCHDryRun horizontal pump contributes to the success of the dry running vertical Bungartz magnetic pumps MPCV and MPAT, which have been employed in applications for many years, so that they now belong to the broad range of chemical pumps with standard fitting dimension.

APPLICATION AREAS.

- toxic media with particular demands on the shaft seal
- pumping liquids containing solid parts
- gas-containing pumping liquids

ADVANTAGES.

- continuously dry running
- robust and free of wear and tear
- low vibrations
- maintenance-free
- reliable and durable

WARRANTY OF SERVICEABILITY.

The robust, anti-friction bearing with lifetime lubrication and the dry running magnetic drive work maintenance-free for 3 years, irrespective of the pumping medium.

PUMPING MEDIUM.

As the bearing and the magnetic drive have no contact with the pumping medium and as different impeller geometries are available, this all-purpose magnetic-driven pump can be operated for applications that are almost independent of the use of liquids.

PRODUCT TEMPERATURES.

Between the back of the impeller and the shaft bearing there is a product-free labyrinth area through which sealing gas flows. This sealing results in a high temperature gradient and thus a lower temperature of the bearing. A heatable pump casing is used for melts.

RANGE OF PERFORMANCE.

